

По вопросам продаж и поддержки обращайтесь:

Архангельск (8182)63-90-72	Краснодар (861)203-40-90	Санкт-Петербург (812)309-46-40
Астана (7172)727-132	Красноярск (391)204-63-61	Саратов (845)249-38-78
Астрахань (8512)99-46-04	Курск (4712)77-13-04	Севастополь (8692)22-31-93
Барнаул (3852)73-04-60	Липецк (4742)52-20-81	Симферополь (3652)67-13-56
Белгород (4722)40-23-64	Магнитогорск (3519)55-03-13	Смоленск (4812)29-41-54
Брянск (4832)59-03-52	Москва (495)268-04-70	Сочи (862)225-72-31
Владивосток (423)249-28-31	Мурманск (8152)59-64-93	Ставрополь (8652)20-65-13
Волгоград (844)278-03-48	Набережные Челны (8552)20-53-41	Сургут (3462)77-98-35
Вологда (8172)26-41-59	Нижний Новгород (831)429-08-12	Тверь (4822)63-31-35
Воронеж (473)204-51-73	Новокузнецк (3843)20-46-81	Томск (3822)98-41-53
Екатеринбург (343)384-55-89	Новосибирск (383)227-86-73	Тула (4872)74-02-29
Иваново (4932)77-34-06	Омск (3812)21-46-40	Тюмень (3452)66-21-18
Ижевск (3412)26-03-58	Орел (4862)44-53-42	Ульяновск (8422)24-23-59
Казань (843)206-01-48	Оренбург (3532)37-68-04	Уфа (347)229-48-12
Калининград (4012)72-03-81	Пенза (8412)22-31-16	Хабаровск (4212)92-98-04
Калуга (4842)92-23-67	Пермь (342)205-81-47	Челябинск (351)202-03-61
Кемерово (3842)65-04-62	Ростов-на-Дону (863)308-18-15	Череповец (8202)49-02-64
Киров (8332)68-02-04	Рязань (4912)46-61-64	Ярославль (4852)69-52-93
	Самара (846)206-03-16	

Единый адрес: omb@nt-rt.ru **Веб-сайт:** www.orbtm.nt-rt.ru

Портативные пилы Guillotine ORBITALUM. Техническое описание



E.H. WACHS®

Superior Equipment. Complete Support.™



Fast setup and cutting, both horizontally or vertically.



Easy setup, vertical or horizontal.



Quick cold cuts, minimal clearance.



Portable, rugged design.



Long blade life.



Portable Pipe Saws

- Rugged yet compact design requires minimal clearances
- Four models cut from DN 50 - 800 (2" - 32")
- Fast setup and cutting, both horizontally or vertically
- Pneumatic, hydraulic and electric drive options
- Optional autofeed and autoclamping on select models

Guillotine

Super C, Model D, Super D, Goliath

E.H. WACHS family of portable Guillotine® pipe saws are designed to cold cut DN 50 - 800 (2" - 32") pipe, as well as solids such as bar stock, rails and beams. Their compact design and easy setup make it the ideal saw for contractors, pipeline operations, refineries, petrochemical and processing plants and anywhere a fast, safe cut is needed. In use virtually everywhere, they're strong yet light, simple to mount, simple to operate and simply bulletproof.

Easy setup, vertical or horizontal

Installation time is approximately 5 minutes! A chain pipe vise clamps the Guillotine Saw to the pipe. The machined cast iron "V"-saddle base assures square cuts at right angles. It can be mounted on horizontal as well as vertical piping, in any position.

Quick cold cuts, minimal clearance

The Guillotine Saws require minimal clearance (the model Super C needs as little as 38.1 mm (1.5") on one side of the pipe). All models feature finger tip feed control. The pipe is cold cut in a matter of minutes. A 152.4 mm (6") standard wall steel pipe is cut in only 6 minutes. A 406.4 mm (16") diameter 12.7 mm (0.5") wall steel pipe is cut in about 20 minutes.

Portable, rugged design

The Guillotine Saws combine compact size and light weight with simple, rugged construction for ease of operation and low maintenance.

Long blade life

The high-speed steel blades are easily changed. The unique Guillotine cutting action lifts the blade from the cut on the return stroke, extending blade life.



E.H. WACHS Guillotine

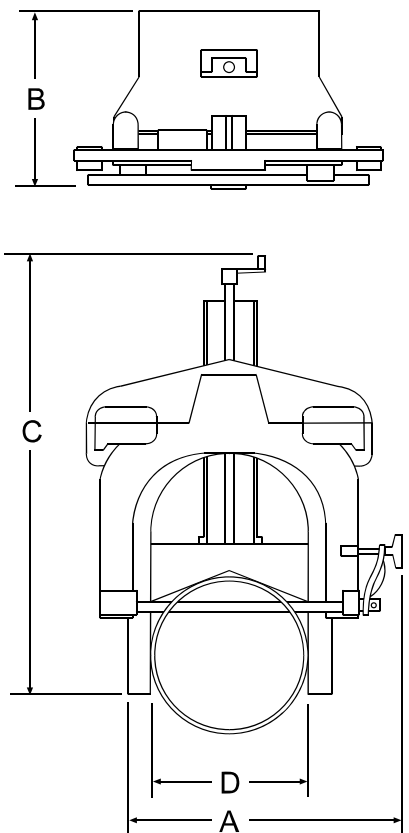

Specifications		Super C	Model D	Super D	Goliath
Machine capacity	[mm]	DN 50 - 300	DN 150 - 450	DN 250 - 600	DN 400 - 800
	[inch]	2 - 12	6 - 18	10 - 24	16 - 32
Solids through	[mm]	324	473	622	838
	[inch]	12.75	18.625	24.5	33
Clearance overall width (on one side min.)	[mm]	711 (63.5)	813 (76)	991 (76)	1.676
	[inch]	28 (2.5)	32 (3)	39 (3)	66
Weight (operating / shipping)	[kg]	52 / 82	154 / 188	234 / 281	816.5
	[lbs]	115 / 180	340 / 415	515 / 620	1800
Dimension A	[mm]	596,9	794	972	1676.4
	[inch]	23.5	31.25	38.25	66
Dimension B	[mm]	323,85	368	368	635
	[inch]	12.75	14.5	14.5	25
Dimension C	[mm]	800	940	1118	1943
	[inch]	31.5	37	44	76.5
Dimension D	[mm]	337	476	629	838
	[inch]	13.25	18.75	24.75	33
Stroke	[mm]	51	51	102	
	[inch]	2	2	4	
Shipping dimensions (estimated)	[cm]	66 x 74 x 56	160 x 119 x 74		
	[inch]	26 x 29 x 22	63 x 47 x 29		



Specifications		Guillotine, Super C, Model D, Super D, Goliath	
Drive		Air, electric or hydraulic (Goliath only with hydraulic drive)	
Air motor drive	[m ³ /min]	1.4 at 5.0 bar	
	[ft ³ /min]	50 at 85 psi	
Electric drive		15 A, 110 or 220 Volt single phase	
Hydraulic drive	[l/min]	38 at 106 bar	
	[gal/min]	10 at 1500 psi	
Installation time		Approx. 5 minutes	
Controls		Single crank, manual feed. Motor on-off.	
Lubrication		Grease fittings at all wear points	
Finish		Paint	
Standard equipment		<ul style="list-style-type: none"> • Heavy drive (air, electric or hydraulic) • 1 Standard saw blade • Wrench 31.75 mm (1 1/4") • Air lubricator and filter (Air Model) • Steel storage case (Model C and D only) • Lifting eyes (Model D and Super D) • Mounting chains • Manual 	
Optional equipment		<ul style="list-style-type: none"> • Model D transporter truck • Blades: HSS and carbide blades (depending on the machine version) • Lifting frame • Hydraulic bulkhead for remote operation • Autoclamp mechanism • Autofeed 	

Article	Version	Pipe OD		Code	WACHS Ref.-no.		
		[mm]	[inch]				
Guillotine Super C*	Electric, 110 V	DN 50 - 300	2 - 12	924 000 010	24-000-01		
Guillotine Super C	Pneumatic	DN 50 - 300	2 - 12	924 000 020	24-000-02		
Guillotine Super C	Hydraulic	DN 50 - 300	2 - 12	924 000 030	24-000-03		
Guillotine Super C Autoclamp	Hydraulic	DN 50 - 300	2 - 12	on request	–		
Guillotine Super C Autoclamp & Autofeed	Hydraulic	DN 50 - 300	2 - 12	on request	–		
Guillotine Model D*	Electric, 110 V	DN 150 - 457	6 - 18	904 000 010	04-000-01		
Guillotine Model D	Pneumatic	DN 150 - 457	6 - 18	904 000 020	04-000-02		
Guillotine Model D	Hydraulic	DN 150 - 457	6 - 18	904 000 030	04-000-03		
Guillotine Super D	Pneumatic	DN 250 - 610	10 - 24	925 000 010	25-000-01		
Guillotine Super D	Hydraulic	DN 250 - 610	10 - 24	925 000 030	25-000-03		
Guillotine Super D Autoclamp	Hydraulic	DN 250 - 610	10 - 24	on request	–		
Guillotine Super D Autoclamp & Autofeed	Hydraulic	DN 250 - 610	10 - 24	on request	–		
Guillotine Goliath	Hydraulic	DN 400 - 800	16 - 32	on request	on request		
Guillotine Goliath Autoclamp	Hydraulic	DN 400 - 800	16 - 32	on request	–		
Guillotine Goliath Autoclamp & Autofeed	Hydraulic	DN 400 - 800	16 - 32	on request	–		

* Special manufacture unit, contact Orbitalum Tools for price and delivery.

Accessories for Guillotine

Saw blades

Article	Code	WACHS Ref.-no.		
Saw blades for Model C				
Standard blade. For general use (old Code: 1206-6D)	903 405 000	03-405-00		
Saw blades for Model Super C				
Standard blade. For general use.	924 405 000	24-405-00		
Carbide tooth blade. For use on cement lined pipe.	924 405 010	24-405-01		
Saw blades for Model D				
Standard blade. For general use. Old Code: 2306-8D.	904 402 000	04-402-00		
Thin wall blade 4.7 mm (3/16") max. wall. Old Code: 2310-8D.	904 403 000	04-403-00		
Carbide tooth blade. For use on cement lined pipe.	904 405 010	04-405-01		
Saw blades for Model Super D				
Heavy duty blade.	925 402 000	25-402-00		



HSS high-performance blade



Carbide blade for Model Super C and Model D

Miscellaneous accessories and spare parts

Article	To utilize with Guillotine				Code	WACHS Ref.-no.		
	Model C	Super C	Model D	Super D				
Air motor conversion (replaces all obsolete motors)	x				903 414 000	03-414-00		
Lubricator retrofit kit	x	x	x	x	903 500 100	03-500-10		
Spare parts kit	x	x			903 500 010	03-500-01		
Spare parts kit			x		904 500 010	04-500-01		
Spare parts kit				x	925 500 010	25-500-01		
Spare parts kit with air motor			x		904 500 020	04-500-02		
Spare parts kit with air motor				x	925 500 020	25-500-02		
Manual. Electronic version via e-mail available free upon request.	x	x	x	x	903 626 010	03-MAN-01		

Hydraulic Power Pack

Hydraulic Power Pack "SafeQuip", see page 55.

Cutting lubrication

Cutting lubrication "KSS-TOP", see page 32.



По вопросам продаж и поддержки обращайтесь:

Архангельск (8182)63-90-72	Краснодар (861)203-40-90	Санкт-Петербург (812)309-46-40
Астана (7172)727-132	Красноярск (391)204-63-61	Саратов (845)249-38-78
Астрахань (8512)99-46-04	Курск (4712)77-13-04	Севастополь (8692)22-31-93
Барнаул (3852)73-04-60	Липецк (4742)52-20-81	Симферополь (3652)67-13-56
Белгород (4722)40-23-64	Магнитогорск (3519)55-03-13	Смоленск (4812)29-41-54
Брянск (4832)59-03-52	Москва (495)268-04-70	Сочи (862)225-72-31
Владивосток (423)249-28-31	Мурманск (8152)59-64-93	Ставрополь (8652)20-65-13
Волгоград (844)278-03-48	Набережные Челны (8552)20-53-41	Сургут (3462)77-98-35
Вологда (8172)26-41-59	Нижний Новгород (831)429-08-12	Тверь (4822)63-31-35
Воронеж (473)204-51-73	Новокузнецк (3843)20-46-81	Томск (3822)98-41-53
Екатеринбург (343)384-55-89	Новосибирск (383)227-86-73	Тула (4872)74-02-29
Иваново (4932)77-34-06	Омск (3812)21-46-04	Тюмень (3452)66-21-18
Ижевск (3412)26-03-58	Орел (4862)44-53-42	Ульяновск (8422)24-23-59
Казань (843)206-01-48	Оренбург (3532)37-68-04	Уфа (347)229-48-12
Калининград (4012)72-03-81	Пенза (8412)22-31-16	Хабаровск (4212)92-98-04
Калуга (4842)92-23-67	Пермь (342)205-81-47	Челябинск (351)202-03-61
Кемерово (3842)65-04-62	Ростов-на-Дону (863)308-18-15	Череповец (8202)49-02-64
Киров (8332)68-02-04	Рязань (4912)46-61-64	Ярославль (4852)69-52-93
	Самара (846)206-03-16	

Единый адрес: omb@nt-rt.ru **Веб-сайт:** www.orbtm.nt-rt.ru